

Inductive Analog-Sensors

Item group 260



Non-contacting measurement of distance and position

- Distance
- Displacement
- Position
- Edge guiding
- Concentricity
- Centering
- Sorting
- Counting
- Expansion
- Deformation
- Deflection
- Vibration
- Excentricity
- Roll clearance
- Deviation

The inductive analog sensor is suitable for non-contacting measuring of distance or position referred to metals. The measuring principle is based on the physical effect of change of quality of a resonant circuit which is due to eddy current losses in conductive material.

The high-frequency pulsating field of a LC resonant circuit leaves at the active surface of the sensor and is periodically excited by a pulse stage. As soon as electrically conductive material enters the field eddy currents result. Energy is taken from the resonant circuit, and its amplitude and decay time are influenced proportionally to the object distance. A μ -processor serves for integration of the energy of the resonant circuit and determines the resulting output signal.

The electro-magnetic field is non-interacting, i. e. it does not produce any heating in the object to be measured nor does it have magnetic influence. Acc. to function measuring is carried out referring to moved or stationary metals. For fast processes it has to be considered that the periodically excited resonant circuit reaches a measuring rate between 100 and 250 per second.

The robust design in potted housing and easy handling make possible industrial standard solutions as well as sophisticated applications.

By means of two incorporated push-buttons measuring range and individual curve shapes can be programmed. Apart from the measuring value output a serial interface is available.

Distance measuring in case of axial approach of the object to be measured

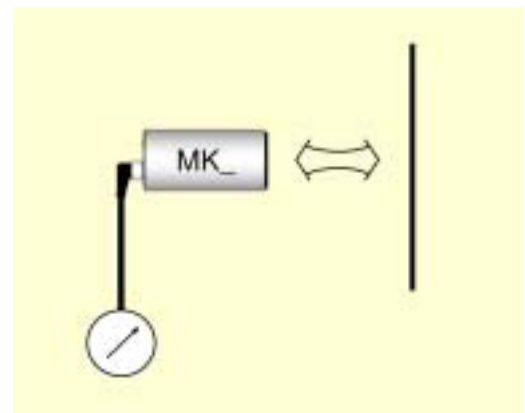
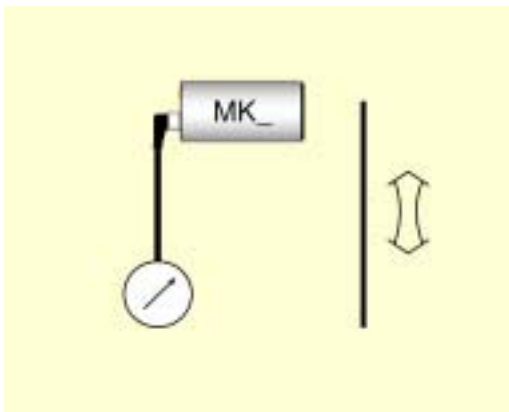

Displacement measuring in case of radial deviation of the object to be measured

Measuring of non-circularity or angle of rotation

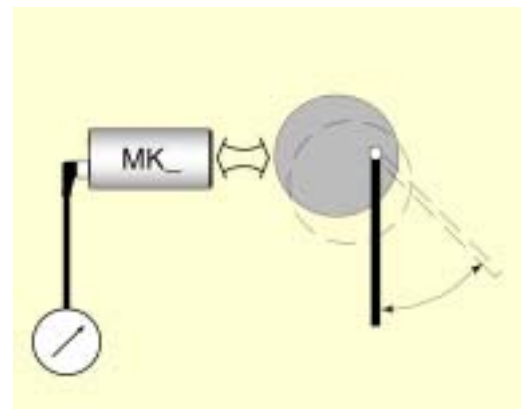
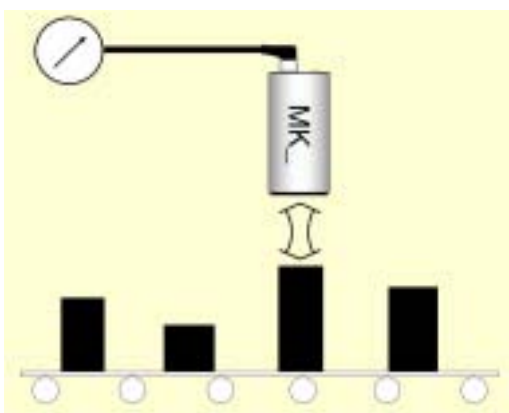

**Selection in the production area:
 Height, surface or material properties**

Type survey

Additional designs on request

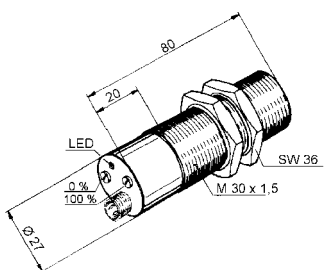
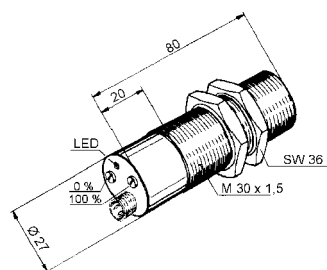
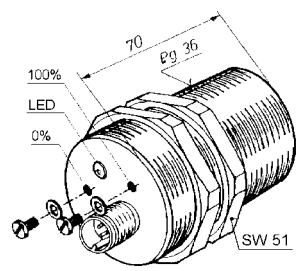
Design:	M 30	M 30	PG 36
Distance range* (Ab):	0 – 10 mm	0 – 15 mm	0 – 20 mm
			
Installation:	flush	non-flush	flush
Response delay:	approx. 15 ms	approx. 15 ms	approx. 15 - 20 ms
Repeat accuracy:	≤ 0,3 %	≤ 0,3 %	≤ 0,3 %
Linearity deviation:	≤ 2,5 %	≤ 1 %	≤ 1 %
Temperature deviation:	≤ 5 %	≤ 5 %	≤ 5 %
Temperature deviation at 50 % Ab	≤ 2,5 %	≤ 1,5 %	≤ 1,5 %
Housing material:	plastic PBT	plastic PBT	brass, nickel-plated
Type 0 – 10 V:	MKL 010.19 S4	MKL 015.19 S4	MKZ 471. 19 S4
Art.-No.:	2482E	2482A	2330A
Type 0 – 20 mA:	MKL 010.190 S4	MKL 015.190 S4	MKZ 471.190 S4
Art.-No.:		2482B	2330B
Type 4 – 20 mA:	MKL 010.194 S4	MKL 015.194 S4	MKZ 471.194 S4
Art.-No.:	2482D	2482C	2330C
Notes:	including RS 485 interface	including RS 485 interface	including RS 485 interface

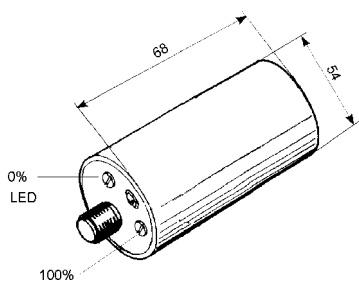
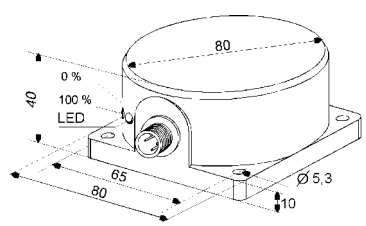
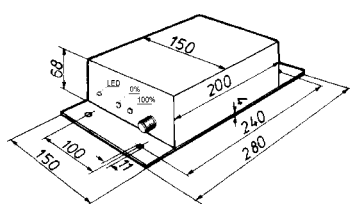
Design:	Ø 54 mm	Ø 80 mm	150 x 200 mm
Distance range* (Ab):	0 – 35 mm	0 – 50 mm	0 – 120 mm
			
Installation:	non-flush	non-flush	non-flush
Response delay:	approx. 15 - 20 ms	approx. 19 - 24 ms	approx. 19 - 24 ms
Repeat accuracy:	≤ 0,3 %	≤ 0,3 %	≤ 0,3 %
Linearity deviation:	≤ 1 %	≤ 2 %	≤ 2 %
Temperature deviation:	≤ 5 %	≤ 7 %	≤ 7 %
Temperature deviation at 50 % Ab	≤ 1,5 %	≤ 1,5 %	≤ 1,5 %
Housing material:	plastic PBT	plastic PBT	plastic PBT
Type 0 – 10 V:	MKH 035.19 S4	MKK 050.19 S4	MKU 215.19 S4
Art.-No.:	2338A	2331A	2159J
Type 0 – 20 mA:	MKH 035.190 S4	MKK 050.190 S4	MKU 215.190 S4
Art.-No.:	2338B	2331F	
Type 4 – 20 mA:	MKH 035.194 S4	MKK 050.194 S4	MKU 215.194 S4
Art.-No.:	2338C	2331G	2159L
Notes:	including RS 485 interface	including RS 485 interface	including RS 485 interface

* The distance area refers to a square steel plate having an edge length of 3 times the max. distance value. Size deviations influence the working range. For other materials the correction factors stated on the next page have to be applied.

Compact analog sensors of series MK_ monitor in a non-contacting manner distance, size or quantity of metallic objects. An integrated microprocessor serves for quick and simple adaption.

- Start and final value of the measuring range programmable.
- Limitation of the distance range utilizing the entire output range
- Reversal of efficiency direction
- Programmable linearization
- Adjustment of the sensor direct by two push-buttons at the application
- Settings as well as transmission of the distance value via serial interface
- Upto 30 analog sensors having a total cable length of upto 1000 m can be connected to one serial interface
- Different connection cable for simply utilising the analog output or for additional utilisation of the serial interface

Technical Data

Distance range adjustable	yes
Load impedance at voltage output	≥ 10K
Load impedance at current output	≤ 560R
Ripple content	≤ 1 %
Output short-circuit protected	yes
Protected against polarity reversal	no
Digital communication	RS 485
Supply voltage	24 V DC ±20 %
Ripple voltage	max. 15 %
Current consumption	≤ 12 mA
Readiness delay	1 s from connection the supply voltage
Resolution	1 ‰ of final value
Ambient temperature	-10 ... +70 °C
Protection class	IP 67
Connection	plug S4 (M12 x 1)
Function display	LED

Diagram of connection

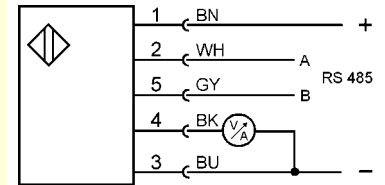

Accessories (not included in scope of supply)

Description	Type	Art.-No.
3-pole angle connector with moulded connection cable of 5 m length for analog evaluation only	ST 041/3-5	9841R
alternatively for ST041/3-5: 5 pole angle connector with moulded connection cable of 5 m length for additional use of RS 485 interface	ST 041/5-5	9841Q

Please contact us for our application advice service.

We know many solutions.

Correction factors

Ab	Metal foil	Steel	Stainless steel	Brass	Aluminium	Copper
	x 1,20	x 1,0	x 0,85	x 0,5	x 0,45	x 0,40

Survey of product group



Since 1979 Proxitron has been developing and manufacturing sensors. Sturdy construction and continuous quality control guarantee maximum reliability

www.proxitron.de

Inductive proximity switch

- WG 210 Sensing distance < 20 mm
- WG 220 Sensing distance 20-60 mm
- WG 230 Sensing distance 60-120 mm
- WG 240 Sensor strips
- WG 241 Surface sensors
- WG 250 Ring-sensors
- WG 260 Inductive Analog-sensors and evaluation electronics

Other Sensors

- WG 100 Capacitive Sensors
- WG 510 Piros Light barriers
- WG 610 Piros Infrared-Sensors
- WG 620 Piros for fibre optics
- WG 630 Piros Infrared pyrometers
- WG 800 Flow-sensors for air
- WG 830 Flow-sensors

Compact analog sensor in stainless steel casing. The object distance can be transferred via the analogous output.

Range of distance and linearization for different applications can be individually set by two push-buttons.

Technical Data

Type	MKZ 120.194
Art.-No.	2159K
Distance range max. Ab	0 - 120 mm*
Distance range adjustable	yes
Output	4 – 20 mA
Load impedance max.	560R
Ripple content	≤ 1%
Output short circuit protected	yes
Reverse polarity protection	no
Location at metal	flush mount
Supply voltage	24 V DC ± 20%
Ripple voltage	max. 15 %
Current consumption	≤ 12 mA
Readiness time	1 s
Response delay	approx. 20 ms
Resolution	1 ‰ of final value
Repeatability	≤ 0,3 %
Error of linearity	≤ 3 %
Error of temperature	≤ 10 %
Ambient temperature	-10 ... +70 °C
Protection class	IP 65
Connection	2 m POKT Therm Cable
Function display	Duo-LED
Housing material	stainless steel 1.4301

*Referred to measuring plate steel ST37, 1 mm thick 250 x 250 mm. Deviations of material and size of the object to be measured influence the range of operation.

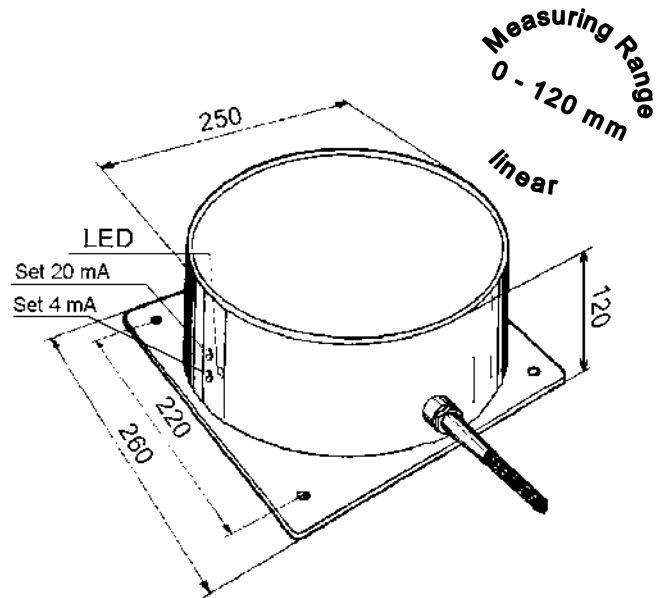
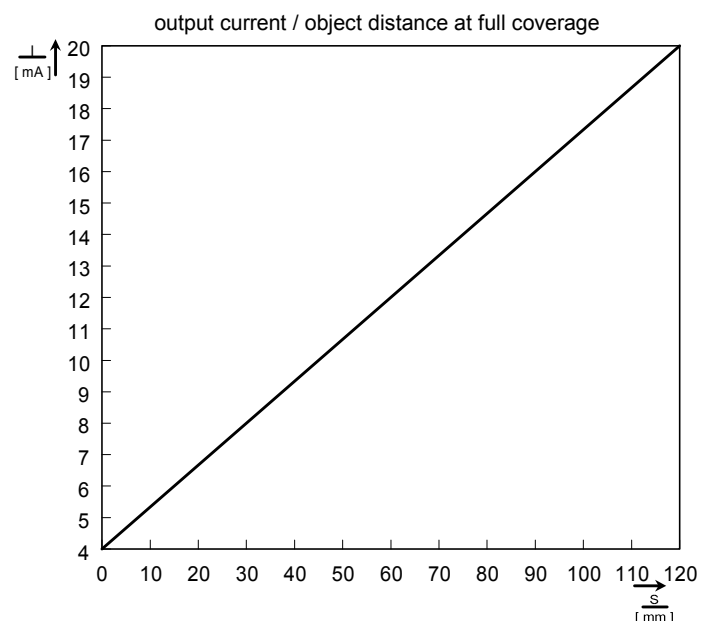
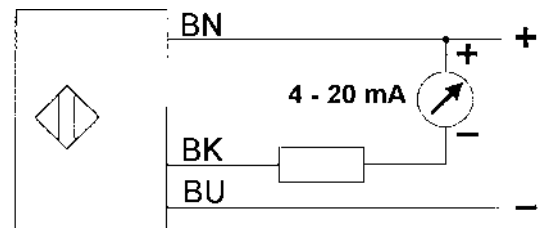

Diagram of Connection



Mobile Measuring station MSZ 002 consisting of a lockable measuring case with mains switch, charging regulator and accumulator as well as operation switch, processor blank with interface adaption and display.

The unit determines and stores upto 4000 measuring values. After measuring the data can be transferred into a PC via a serial interface.

Technical Data

Mains voltage	230 V AC reversible 115 V AC
Power absorption	180 mA
Accu	12 V / 3 Ah
Operation time without mains	approx. 12 hours
Charging time	approx. 12 hours
Display	4 lines with 20 digits
Gap indication	49,00 to 79,00 mm
Resolution	1/100 mm
Keyboard	alpha-numerical
	Basic setting 0 to 9
	Password A - P
	Function F1 - F5, F9 - F10
Interface sensor	RS 485
Interface PC	RS 232
Fuse Supply	200 / 100 mA
Fuse Operation	500 mA
Ambient temperature	0 to 50 °C
Connection type measuring skid	round plug connector, series 723, binder
Casing	deeply-drawn aluminium case, lockable with carrying handle
Protection type, closed cover	IP 65
Dimensions	411 x 297 x 166 mm
Weight	7 kgs

The Proxitron procedure of non-contact displacement measuring uses the principle of inductive proximity switches. During this procedure the electro-magnetic alternating field of a sensor induces eddy currents into the surface the metallic object to be measured. The transmission of energy changes the vibration behaviour of the oscillator and is evaluated by the electronic control unit. By means of a special modulation procedure the max. possible measuring range is achieved. Sensors with measuring ranges between 0 to 5 and 0 to 150 mm are available. Practically accuracy's between 1-2/10 mm can be reached because of inhomogeneity of the object material regarding alloy and hardness. If very homogenous material is used, accuracy's upto 1/100 mm are possible as well.

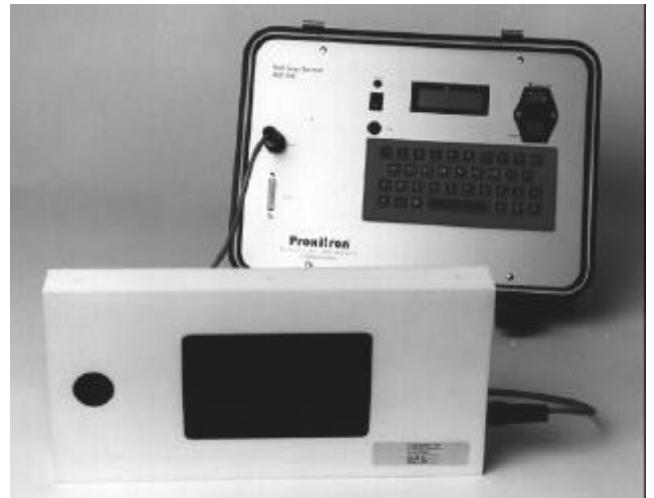

The mobile measuring station MSZ 002 is suitable for operation with 1 or 2 sensors. The internal battery is capable of providing 12 hours operation.

The movable measuring skid MAZ 002 fitted with 2 sensors is moved through the strand guide of a continuous casting plant. Each sensor detects the distance to the rolls in passing. The MSZ computer determines and stores the min. gaps between the rolls. The internal display always shows the last three gap values. It is possible to store up to 2048 gaps in the integrated Flash-ROM (permanent) and to read them at any time. Communication with the PC is effected via a RS232 interface.

Thanks to the menu-guided operation the roll gap sensor can be applied comfortably and adjusted to the application in question. The MSZ 002 can be configured to operate in German, English and Spanish.

The measuring skid MAZ 002 consists of two sensors arranged axially in opposite measuring direction. The A to D converter continuously produces the measuring values for both sensors which are transmitted to the mobile measuring station via a RS485 interface and a connection cable.

Measuring accuracy and linearity are influenced by shape and material of the measuring objects. The system is delivered configured to measure rolls 150 mm diameter made from X20C13. In case of considerable deviations from this basic setting this set-up can be changed and stored in the PC. This change can only be accessed via the password protected extended programming menu. Return to basic setting is possible at any time.

Proximity switch with speed monitoring function in M 30 plastic casing.

For monitoring the operating frequency for control of slip, belt rupture, breakage or overload of conveyor belts, worm drives, mixture plants, pumps etc.

The comfortable TEACH-IN function allows programming of speed and start-up time.

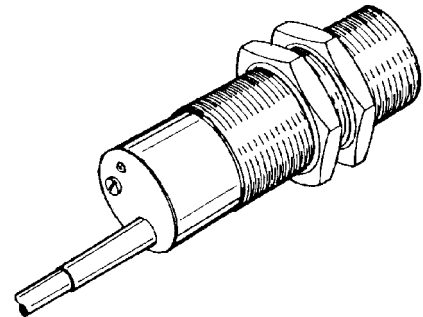

Technical Data

Type	IDL 015.28 G
Art.-No.	2473A
Rated pulse range programmable	5...6000 puls./min.
Rated operating distance (Sn)	15 mm
Output 2 speed controller	PNP Opened if the number of pulses is not reached
Output 4 proximity switch	PNP-normally open closed if the active surface is damped
Target steel St37, 1 mm thick	45 x 45 mm
Location at metal	non flush
Supply voltage (U _B)	10 - 30 V DC
Ripple voltage	max. 15 %
Load current max.	0 - 200 mA
Short- time load current	0,8 A / 100 ms 2 A / 10 ms
Short circuit protection	yes, pulsing
No-load current (I ₀)	10 mA / 24 V DC
Voltage drop (U _d)	1,5 V / 50 mA
Start-up time programmable	0 – 120 s
Switching hysteresis (H) proximity switch	3 - 15 %
Switching hysteresis speed controller	10 %
Ambient temperature	-25 ... +70 °C
Protection class	IP 67
Connection	2 m cable
Function display	LED
Housing material	Plastic PBT
Accessories (not included in the scope of supply)	Art.-No.
programming device Proxibox ID1	2477A

When the supply voltage is applied the output closes for 9 s. Thereafter the sensor evaluates the actual operating frequency. Via the TEACH-IN function the pulse existing at the sensor face can be stored as rated value. If the actually existing value falls below the rated value by $\geq 20\%$, output 2 blocks.

Diagram of Connections

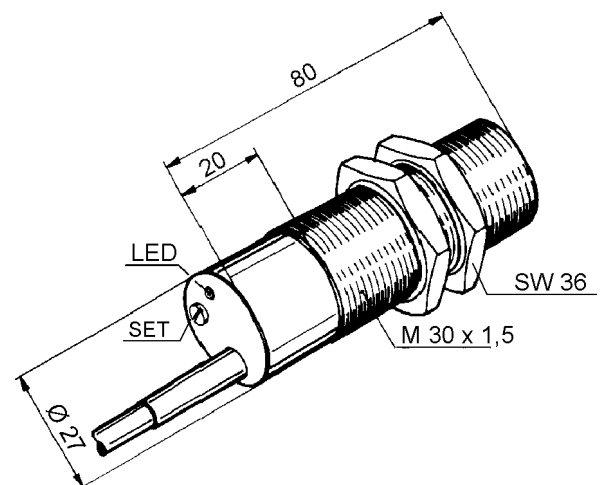
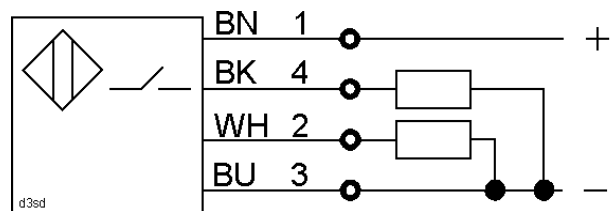

The ZSU speed controller is a monitor of rotating or oscillating machine parts. The speed controller continuously compares the set speed with the actual speed and produces a switching output in the event of excessive variation. The actual speed is monitored by a sensor at the machine in a non-contact method.

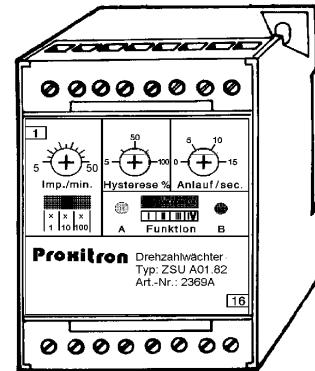

Technical Data

Type	ZSU A01.82
Art.-Nr.	2369A
Range of adjustment	5 - 5000 puls./min.
Supply voltage	230 V AC +/- 10 % or 24 V DC +/- 20 %
Power frequency	45 - 65 Hz (AC)
Power consumption	3,5 VA
Start delay (adjustable)	0 - 15 sec.
Output	2x potential-free changeover relay
Relay contact load	5 A / 240 V AC
Power voltage for external sensor	24 V DC 80 mA max.
Hysteresis (adjustable)	5 - 100 %
Ambient temperature	-25 to +70 °C
Protection class	IP40, recessed screw terminals to VDE 0100 / IP 20
Connection	Terminals up to 4 mm ²
Function display	LED "A" = actual speed below the set speed LED "B" = actual speed above the set speed
Housing	Plastic housing to the regulations of the machine and automotive industry. Mounting to DIN 46121 (2 boreholes) or on a DIN Rail to DIN 46227/EN 50022
Further designs available:	Type:
Supply voltage 110 V AC +/- 10 %	ZSU A01.52

Diagram of Connections

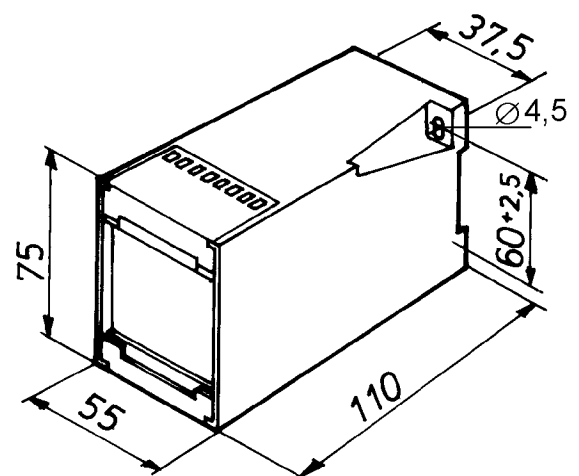
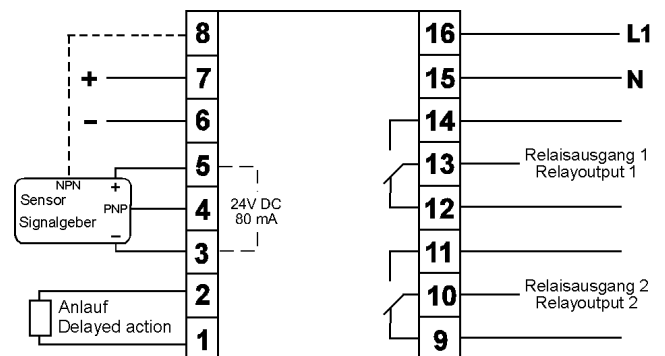

Advantages

- Control of speeds which fall below the set speed or exceed the set speed
- 230V AC or 24V DC
- potential free D.P.D.T. relay
- state of operation indicated by LEDs
- start up delay adjustable
- hysteresis adjustable
- programmable working current or static current behaviour

Usable sensors

- 3 wire, PNP or NPN sensors
- 2 wire, sensors
- magnetic proximity switches
- any type of limit switches
- any type of inductive, magnetic or capacitive proximity sensors
- any type of photoelectric reflex, proximity or through beam sensors

Pulses/min.

The set speed is adjusted by the potentiometer "*Imp./min.*" and by the three-step slide switch. So in the three steps the speed ranges 5 - 50 (x1), 50 - 500 (x10) and 500 - 5000 (x100) pulses per minute are reached.

Hysteresis

The hysteresis is defined as the difference in speed between the relay switching on and off. Hysteresis to the low speed switching point can be adjusted by the potentiometer "*Hysterese%*" from 5% to 100% (hysteresis factor 1,05 to 2,0).

Start Delay

After start up a motor will not be at rated speed for some seconds. To avoid an unwanted alarm this time can be adjusted up to 15 seconds. This delay time is adjusted by a potentiometer "*Anlauf/sec.*" or, alternatively, by an external resistance between the terminals 1 and 2. For external adjustment, the internal potentiometer must be set to 15 seconds.

Start up delay set by external resistance:

Resistance [ohm]	27 K	56 K	120 K	270 K	470 K	1 m	2M2	without
Time [sec.]	1	2	4	6	8	10	12	15

Modes of operation

By means of the four-step slide switch "*Funktion*" different modes of operation are adjustable in order to guarantee compliance with the safety requirements.

Function	Modes of control	Relay		Contact		LED	
		during start	at rated speed	9 / 10 12 / 13	10 / 11 13 / 14	A	B
I	speed falls below rated speed	off	off	close	open		•
II		on	on	open	close		•
III	rated speed exceeded	off	off	close	open	•	
IV		on	on	open	close	•	
during starting both LED`s lighten within preselected time						•	•